

FEATURES:
 REINFORCED MOUNTING SURFACE
 BLACK EDGE TRIM

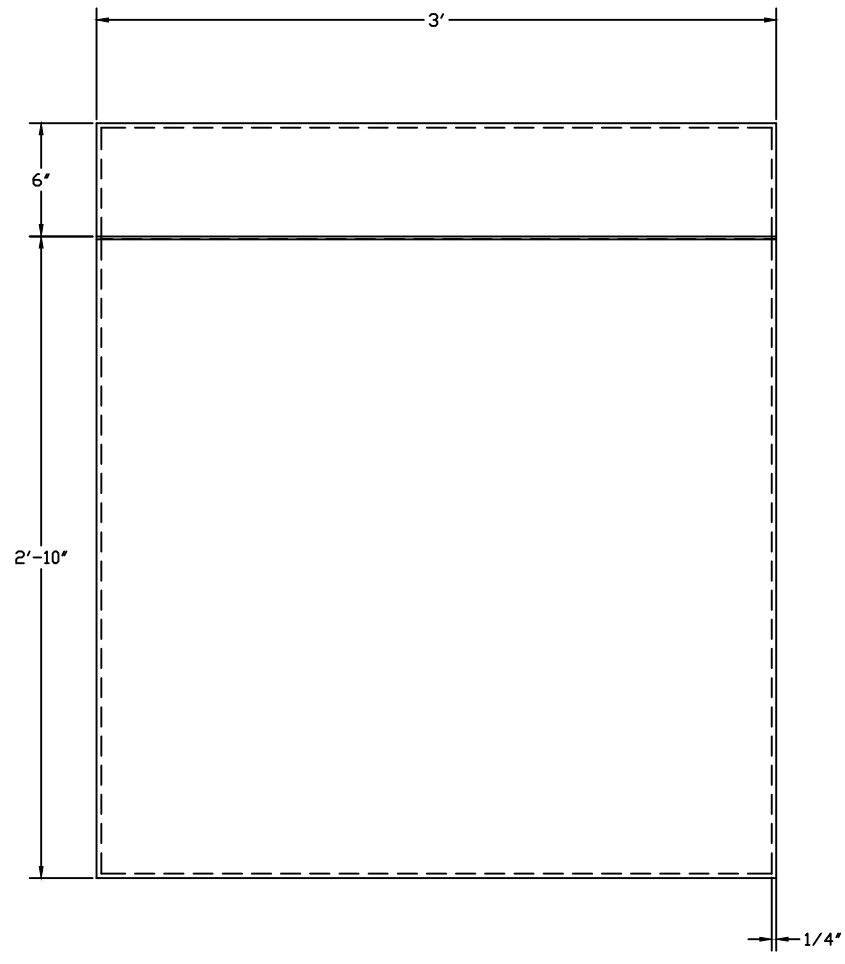

FRONT ELEVATION

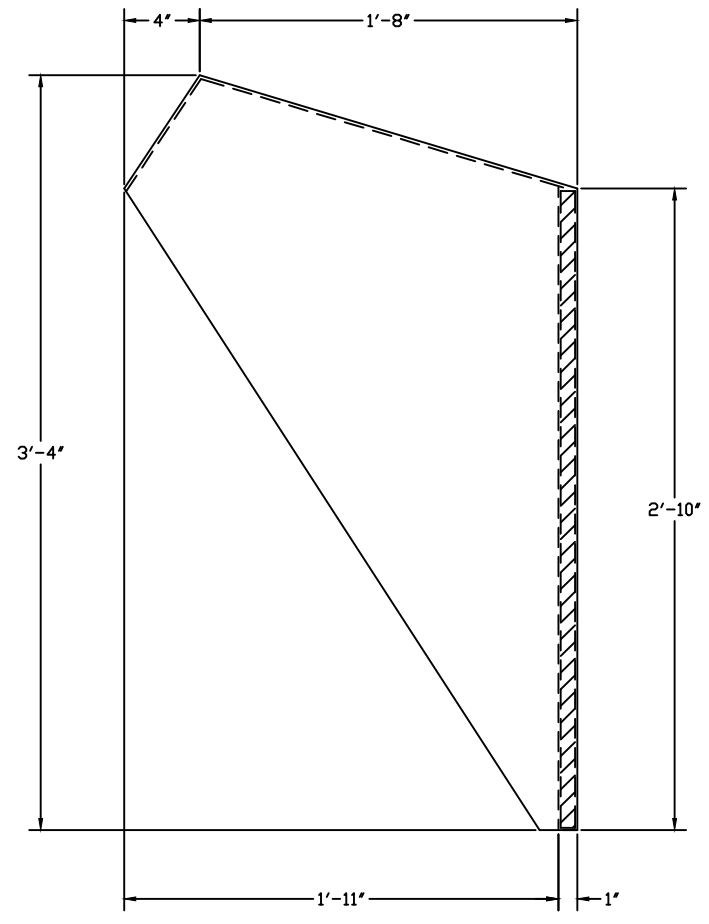

RIGHT ELEVATION

- 1) EDGE TRIM NOT SHOWN FOR CLARITY
- 2) ALL VALUES ARE ACCURATE TO 1/8"

TRACOM FIBERGLASS PRODUCTS	PANEL 30 INSTRUMENT PANEL SHADE, 36" W X 24" D X 40" H WITH REINFORCED MOUNTING SURFACE	
	DWG. NO. PANEL-30-01	REV 0
PROJECT STANDARD PANEL SHADE SIZE	DATE 3/19/15	