

FEATURES: REINFORCED MOUNTING SURFACE  
BLACK EDGE TRIM

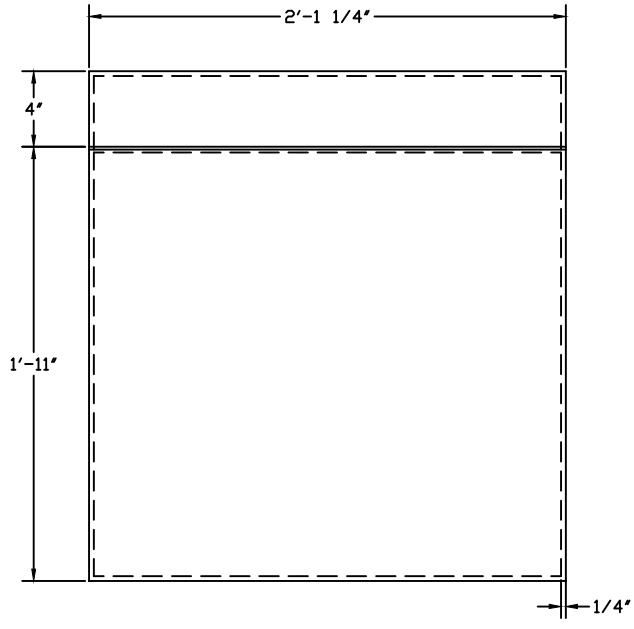

FRONT ELEVATION

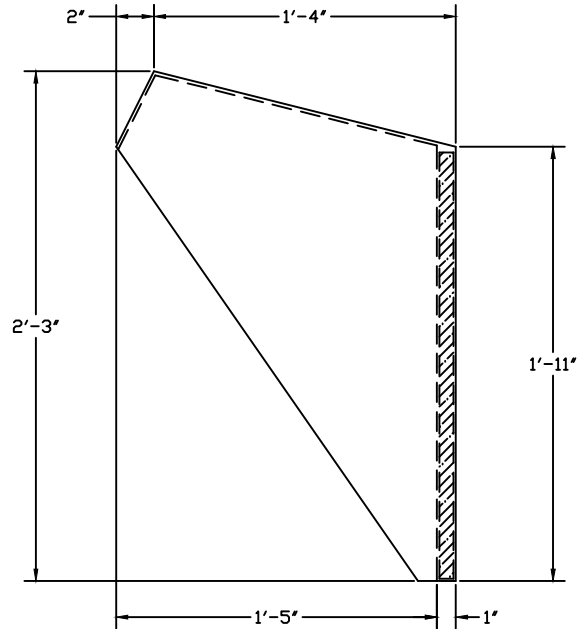

RIGHT ELEVATION

- 1) EDGE TRIM NOT SHOWN FOR CLARITY
- 2) ALL VALUES ARE ACCURATE TO 1/8"

 FIBERGLASS PRODUCTS	PANEL 20 INSTRUMENT PANEL SHADE, 25-1/4" W X 18" D X 27" H WITH REINFORCED MOUNTING SURFACE	
	DWG. NO.	PANEL-20-01
PROJECT	STANDARD PANEL SHADE SIZE	DATE 3/19/15