

FEATURES: REINFORCED MOUNTING SURFACE
BLACK EDGE TRIM

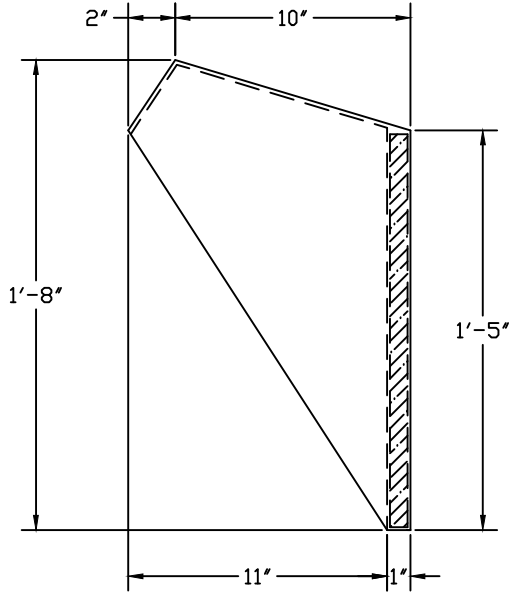
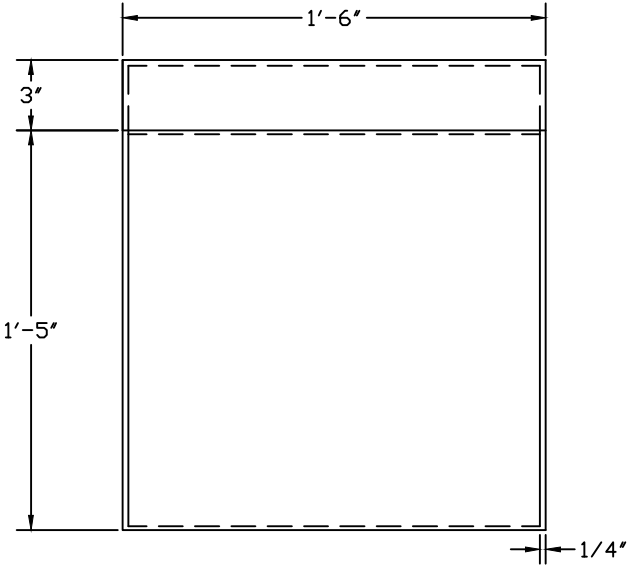

FRONT ELEVATION

RIGHT ELEVATION

- 1) EDGE TRIM NOT SHOWN FOR CLARITY
- 2) ALL VALUES ARE ACCURATE TO 1/8"

TRACOM FIBERGLASS PRODUCTS	PANEL-10 INSTRUMENT PANEL SHADE, 18" W X 12" D X 20" H WITH REINFORCED MOUNTING SURFACE	
	DWG. NO. PANEL-10-01	REV 0
PROJECT	STANDARD PANEL SIZE	DATE 3/19/15