

FLOW METER:	ULTRASONIC - (BY OTHERS)
CONNECTION:	12" DIA. C.I./PVC PIPE
ACCESSORIES:	STAFF GAUGE (AD/ENGLISH)
	FRP GRATING
	6" x 6" SENSOR BEAM CUT-OUT

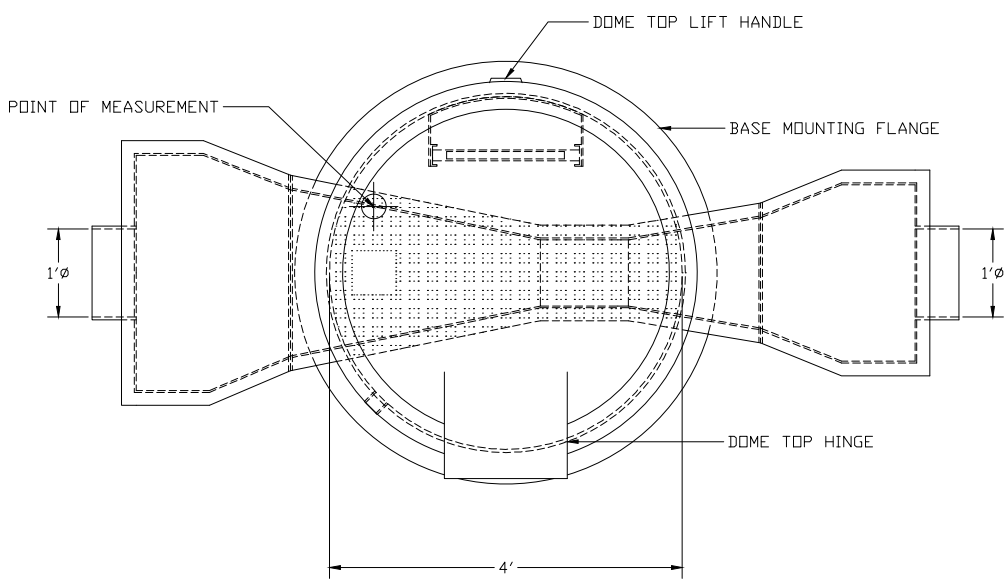

PLAN VIEW

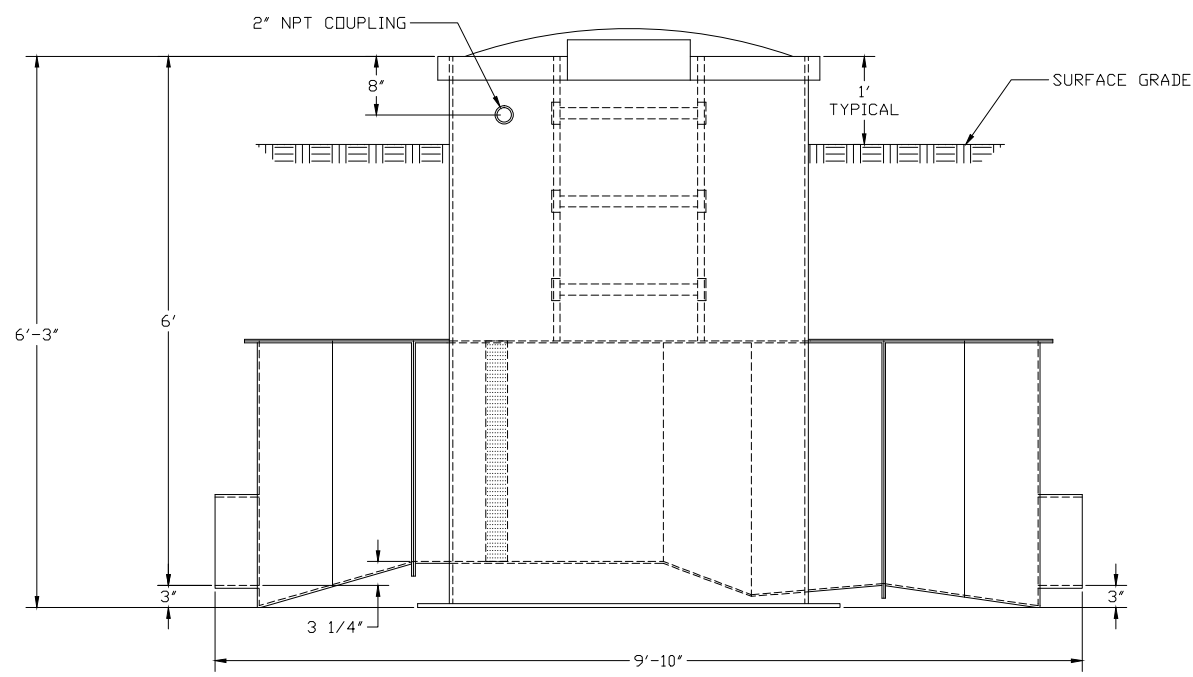

ELEVATION VIEW

1) FLOW IS FROM LEFT TO RIGHT

 FIBERGLASS PRODUCTS	METERING MANHOLE, 48 INCH DIA., DOME TOP STYLE, 9" PARSHALL FLUME, 12" PIPE STUBS, STAFF GAUGE (TENTHS) (RIGHT), AND FRP GRATING WITH SENSOR BEAM CUT-OUT	
	DWG. NO. MH-48-D-PAR09-P12-N-ER-N-G-A	REV 0
PROJECT	DATE 8/31/09	