

FLOW METER:	N/A
CONNECTION:	10" DIA. C.I./PVC PIPE
ACCESSORIES:	NONE

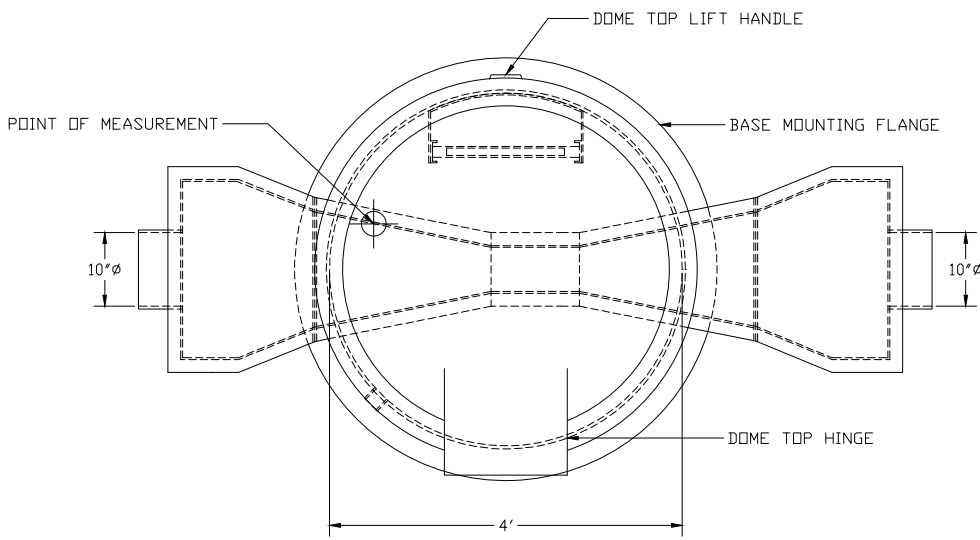

PLAN VIEW

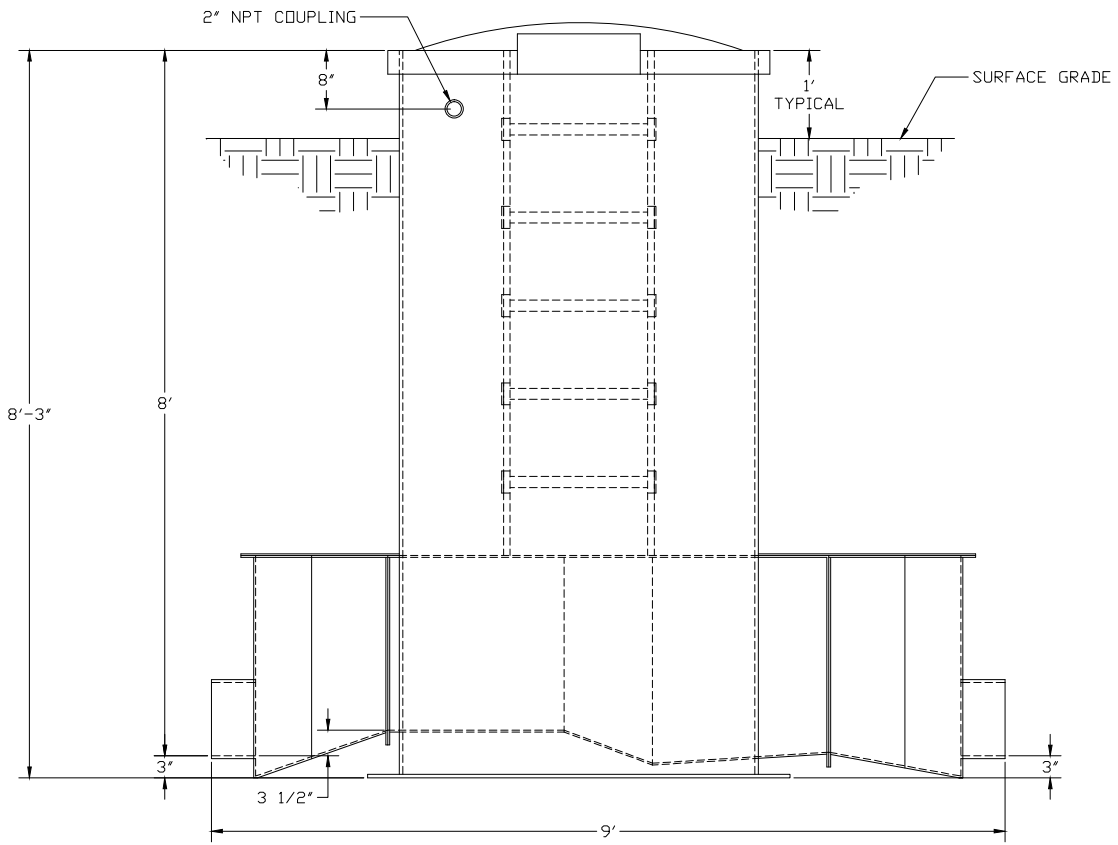

ELEVATION VIEW

1) FLOW IS FROM LEFT TO RIGHT

 FIBERGLASS PRODUCTS	METERING MANHOLE, 48 INCH DIA., DOME TOP STYLE, 6" PARSHALL FLUME WITH 10" PIPE STUBS	
	DWG. NO. MH-48-D-PAR06-P10-N-N-N-N-N	REV 0
PROJECT	DATE 10/28/10	