

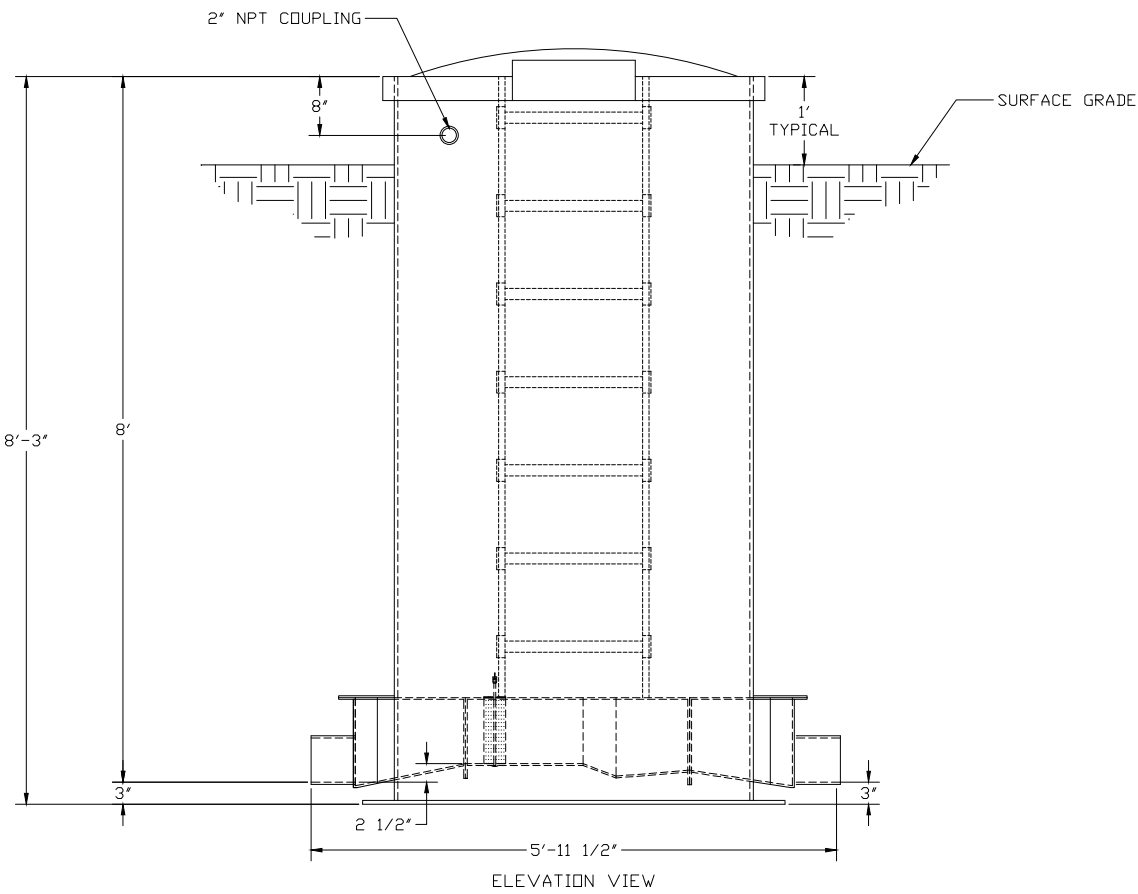

FLOW METER:	BUBBLER -- (BY OTHERS)
CONNECTION:	6" DIA. C.I. / PVC PIPE
ACCESSORIES:	STAFF GAUGE (AD/ENGLISH) SS BUBBLE TUBE

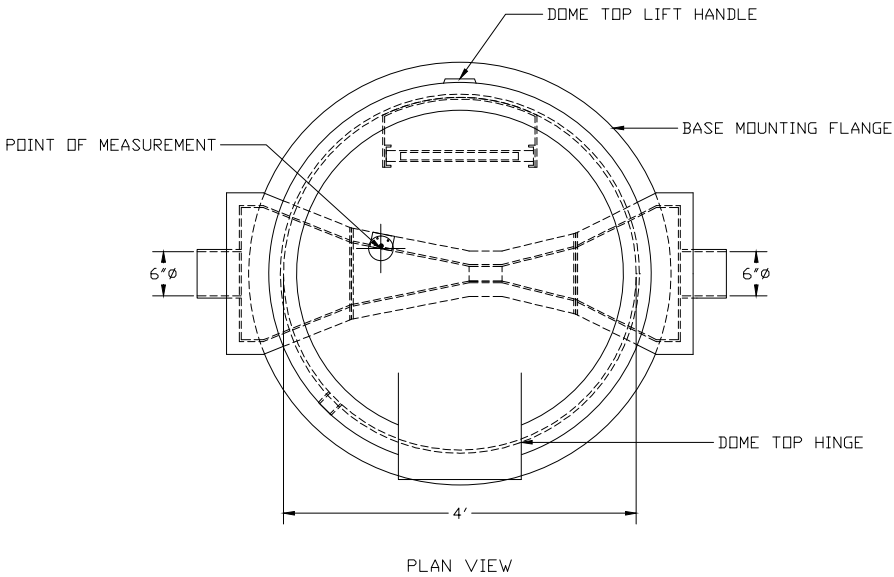

1) FLOW IS FROM LEFT TO RIGHT

 FIBERGLASS PRODUCTS	METERING MANHOLE, 48 INCH DIA., DOME TOP STYLE, 2" PARSHALL FLUME, 6" PIPE STUBS, STAFF GAUGE (TENTHS) (RIGHT), AND BUBBLE TUBE (LEFT)	
	DWG. NO. MH-48-D-PAR02-P6-N-ER-BL-N-N	REV 0
PROJECT	DATE 7/21/04	