

FLOW METER:	N/A
CONNECTION:	18" C.I./PVC PIPE
ACCESSORIES:	STAFF GAUGE (AD/ENGLISH)

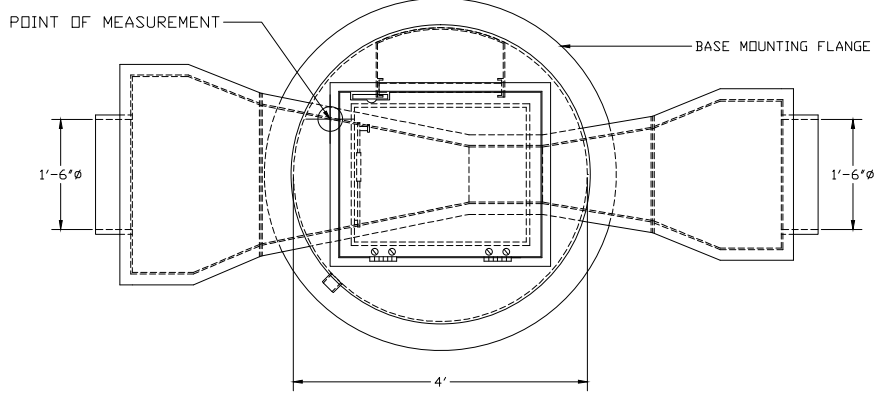

PLAN VIEW

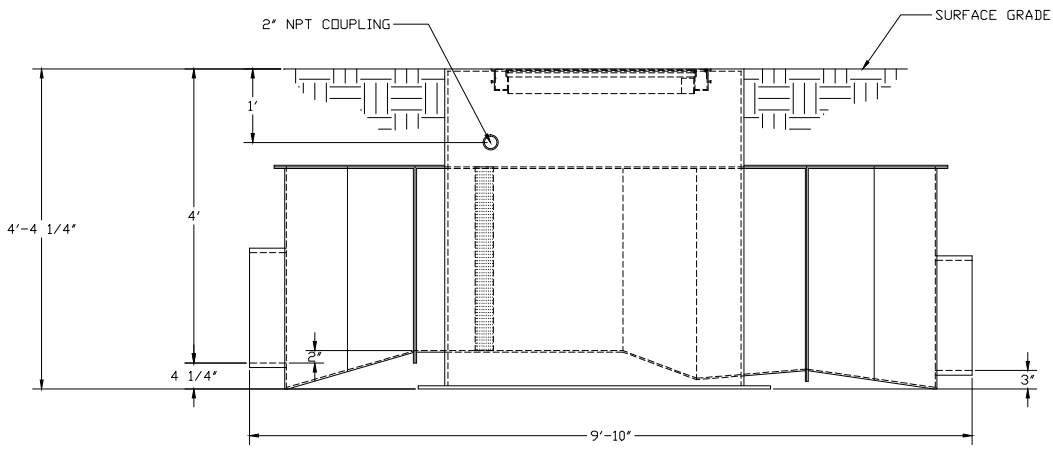

ELEVATION VIEW

1) FLOW IS FROM LEFT TO RIGHT

 FIBERGLASS PRODUCTS	METERING MANHOLE, 48" INCH DIA., ALUMINUM HATCH STYLE, WITH 30" W X 24" D NON-WATERTIGHT HATCH, 9" PARSHALL FLUME, 18" PIPE STUBS, AND STAFF GAUGE (TENTHS) (RIGHT)	
	DWG. NO. MH-48-ALNWT3024-PAR09-P18-N-ER-N-N-N	REV 0
PROJECT TOWN OF FRASER FRASER, CO	DATE 5/4/05	