

FLOW METER:	ULTRASONIC - (BY OTHERS)
CONNECTION:	4" DIA. C.I./PVC PIPE
ACCESSORIES:	STAFF GAUGE (AD/ENGLISH)

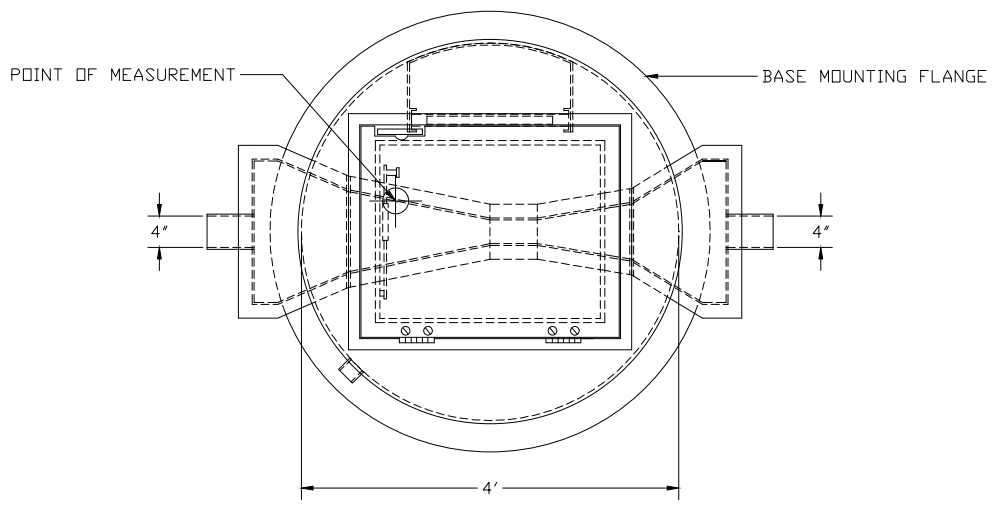

PLAN VIEW

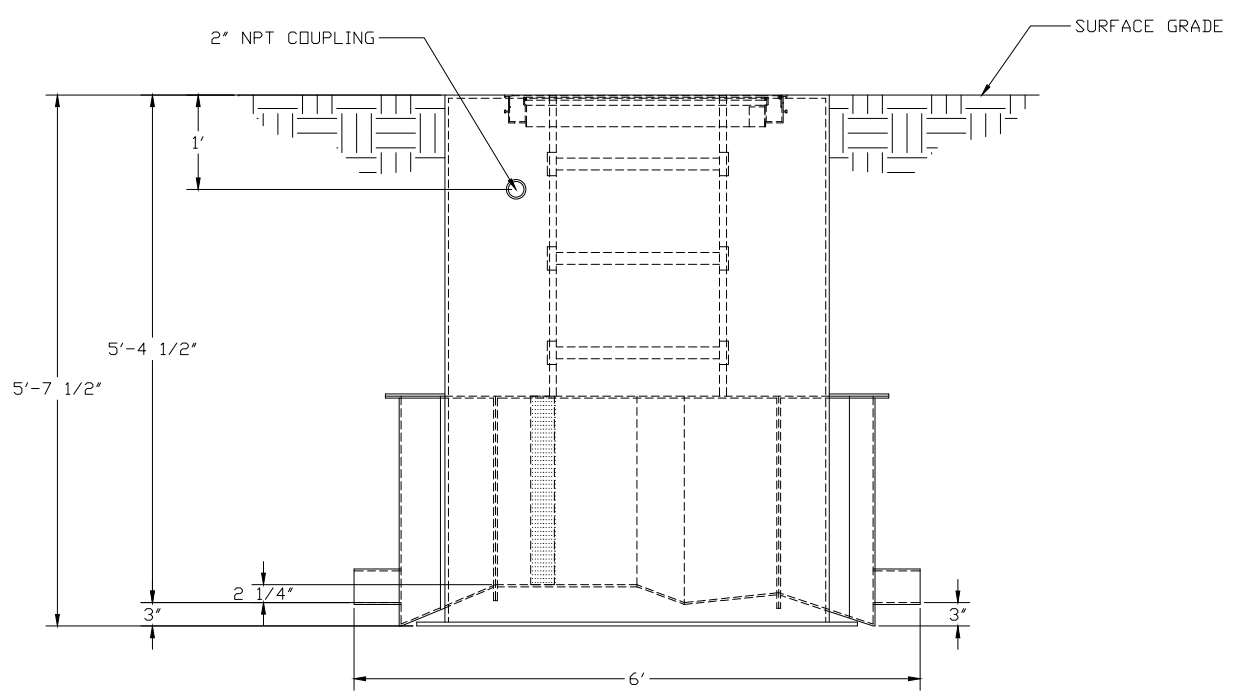

ELEVATION VIEW

- 1) FLOW IS FROM LEFT TO RIGHT
- 2) ANCHOR BOLTS BY OTHERS
- 3) BOTH MANHOLES TO BE IDENTICAL

TRACOM FIBERGLASS PRODUCTS	METERING MANHOLE, 48 INCH DIA., ALUMINUM HATCH STYLE, 30" W X 24" D NON-WATERTIGHT HATCH, WITH 3" PARSHALL FLUME, 4" PIPE STUBS, AND STAFF GAUGE (TENTHS) (RIGHT)	
	DWG. NO. MH-48-ALNWT30X24-PAR03-P4-N-ER-N-N-N	REV 0
PROJECT	TOYOTA MOTOR MANUFACTURING TEXAS SAN ANTONIO, TX	DATE 3/6/06