

EXTERIOR COLOR:	#1555 WHALE BONE
INTERIOR COLOR:	#1555 WHALE BONE
FINISH:	SATIN
HDR:	SOUTHCO TYPE 44 LATCHES
ACCESSORIES:	NONE

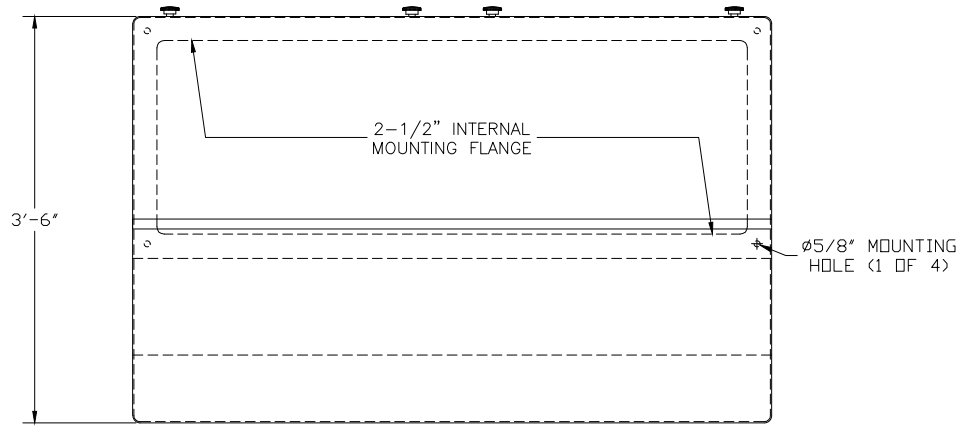

PLAN VIEW

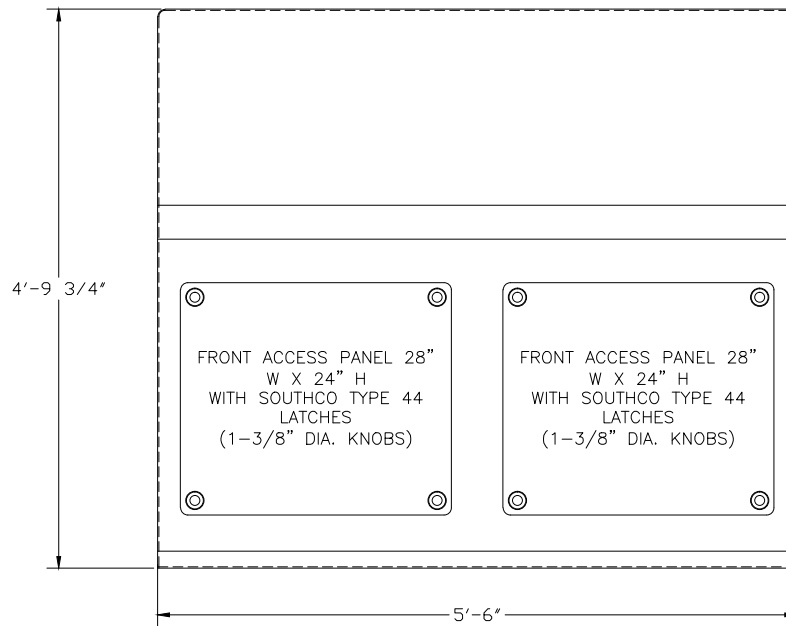

FRONT ELEVATION

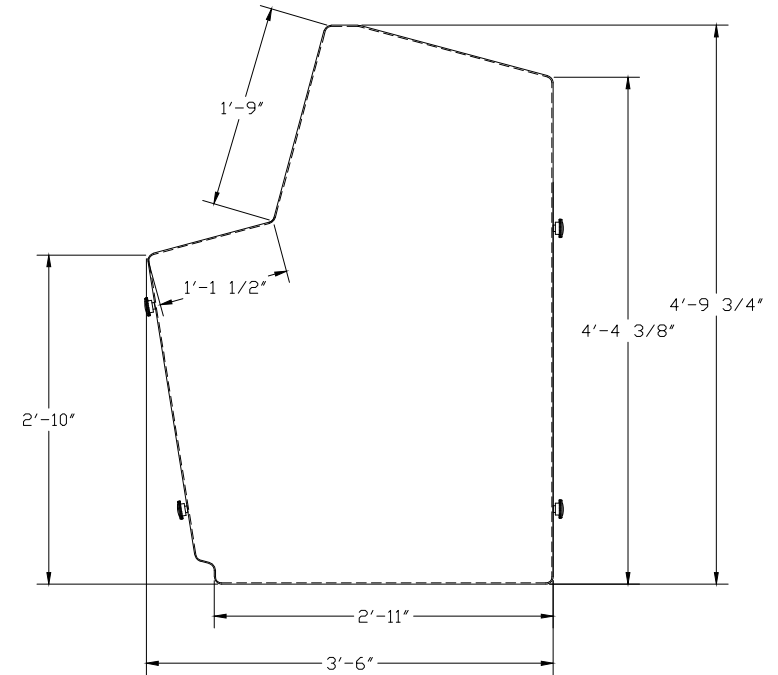

RIGHT ELEVATION

- 1) (2) FRONT ACCESS PANELS (28" W X 24" H)
- 2) (2) REAR ACCESS PANELS (28" W X 32" H)

**TRACOM**  
FIBERGLASS PRODUCTS

SERIES 2500 CONTROL CONSOLE, 66" W X 42" D X 57-3/4" H, WITH SATIN WHALE BONE GEL COAT

DWG. NO. CON-HB-66-S-1555-N-N-N

REV 0

PROJECT

STANDARD CONSOLE SIZE

DATE 8/9/04