

FLOW METER:	N/A
CONNECTION:	N/A
HDR:	1" X 1" PULTRUSION
ACCESSORIES:	NONE

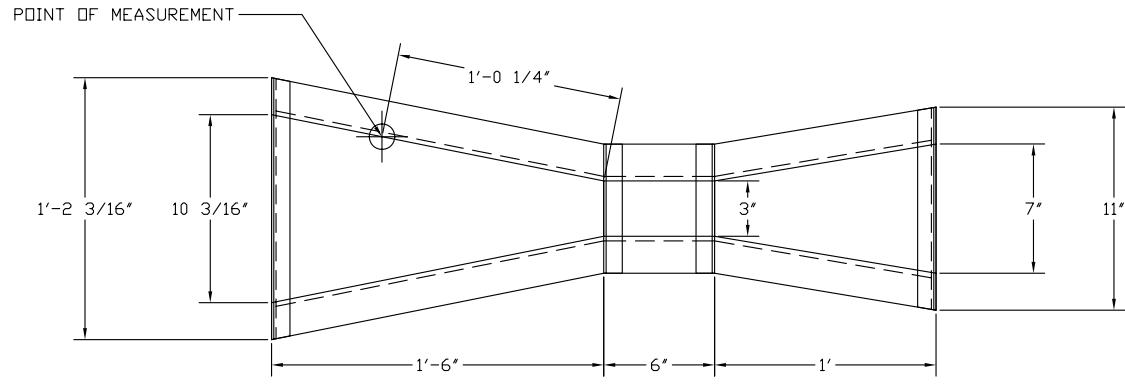

PLAN VIEW

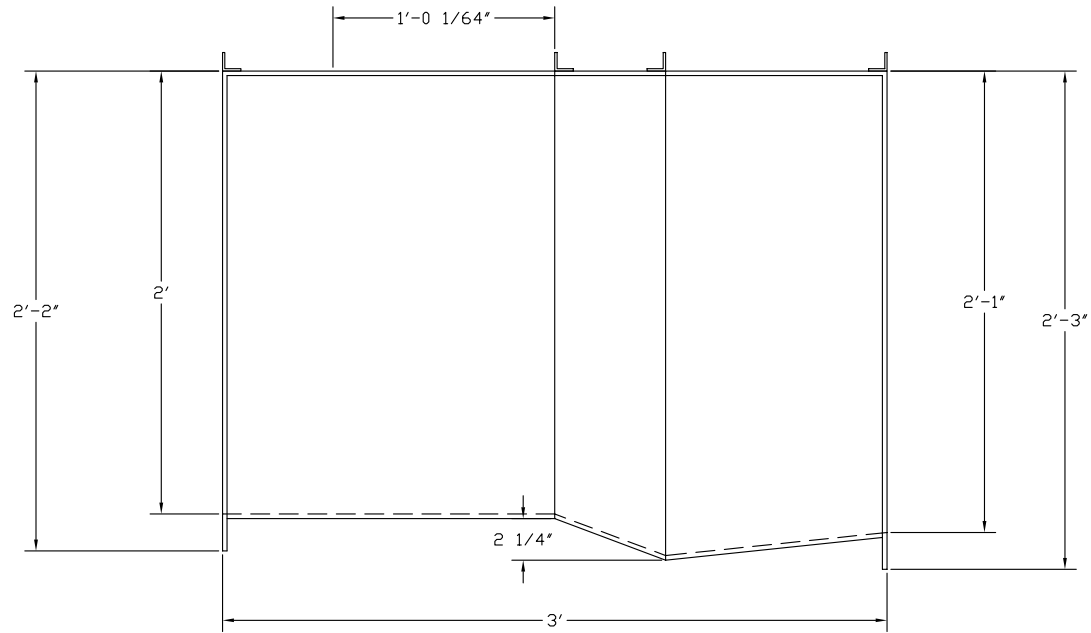

RIGHT ELEVATION

1) FLOW IS FROM LEFT TO RIGHT

TRACOM
FIBERGLASS PRODUCTS

PARSHALL FLUME, SIZE 3"

DWG. NO. PAR-3-N-N-N-N-N-N

REV 0

PROJECT STANDARD FLUME SIZE DATE 8/30/04