

FLOW METER:	N/A
CONNECTION:	6" DIA. C.I./PVC PIPE
HDR:	1" X 1" PULTRUSION
ACCESSORIES:	NONE

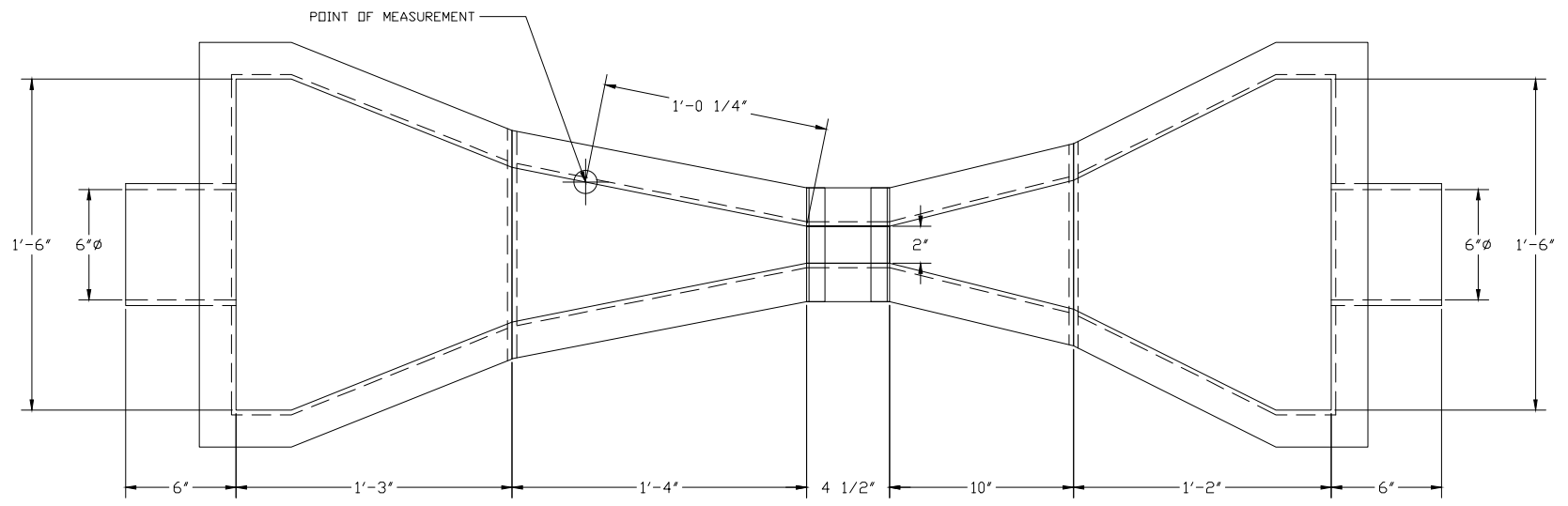

PLAN VIEW

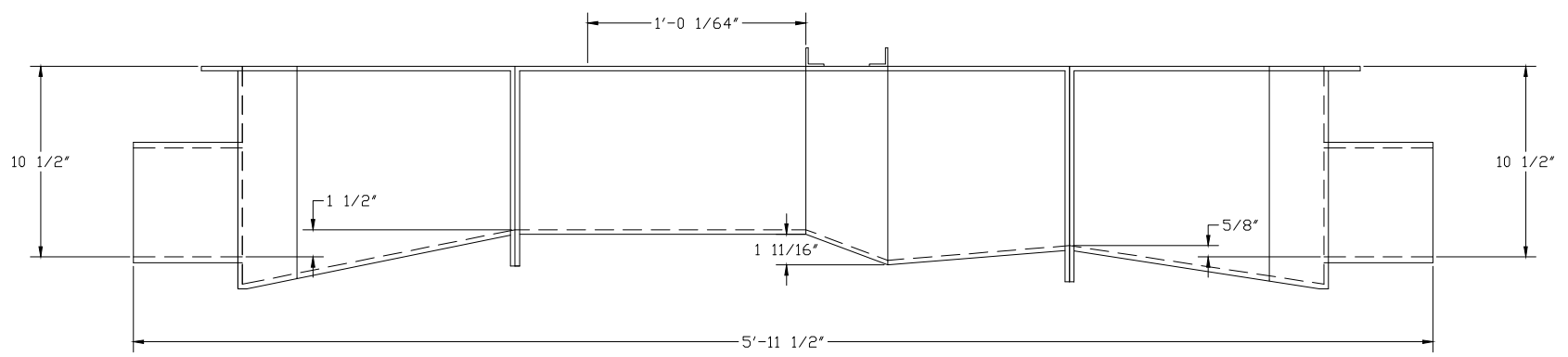

RIGHT ELEVATION

1) FLOW IS FROM LEFT TO RIGHT

 FIBERGLASS PRODUCTS	PARSHALL FLUME, SIZE 2", WITH INLET AND OUTLET END ADAPTERS, AND 6" PIPE STUBS	
	DWG. NO. PAR-2-B-P6-N-N-N-N	REV 0
PROJECT STANDARD FLUME SIZE	DATE 8/19/08	