

FLOW METER:	N/A
CONNECTION:	N/A
HDR:	2" X 2" PULTRUSION
ACCESSORIES:	NONE

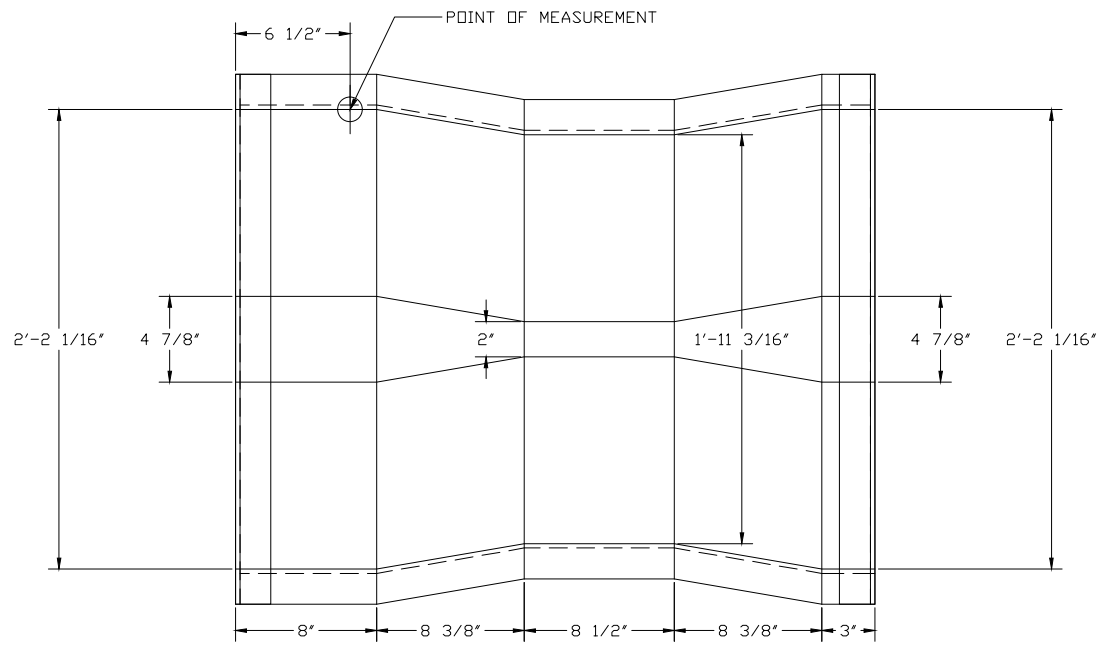

RIGHT ELEVATION

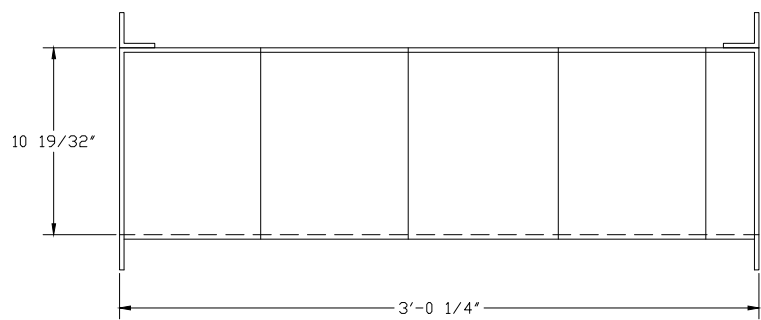

RIGHT ELEVATION

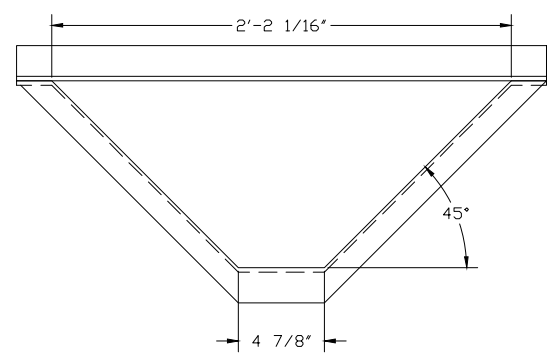

END ELEVATION

1) FLOW IS FROM LEFT TO RIGHT

	2" 45° WSC TRAPEZOIDAL FLUME	
	DWG. NO.	TRAP-245-N-N-N-N-N-N
PROJECT	STANDARD FLUME SIZE	DATE 4/28/03
		REV 0